

NEUTRALIZING TANK

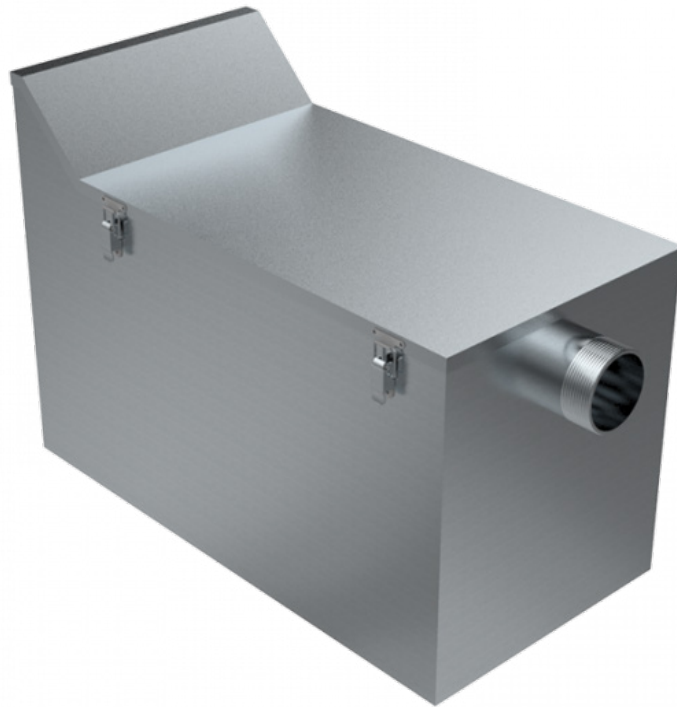

features and benefits

- Purpose built to suit your application
- Manufactured from 316 stainless
- Made to any size (102 L standard)
- Installed above ground
- Quality components for durability
- Quick release lid with gasket seal
- Used in photographic studios and laboratories

about

The *BRITEX Neutralizing Tank* is manufactured from 1.6mm grade 316 stainless steel. This unit is generally used in chemical preparation areas and refineries, where it is necessary to condition liquid waste prior to release into the waste system. Water passes through the marble chips/conditioning block (not supplied) upon entry which neutralises the water pH balance prior to exiting the tank. Available in custom and standard sizes as required.

sample spec. text

BRITEX grade 316 S.S. Neutralizing Tank - 600L x 400W x 450H O/A. 102 Litre capacity. 3 x 20mm wide baffles. Lid to incorporate airtight sealing gasket and be secured with quick release clips - Product Code US-OSNT

*RED TEXT may denote a **variable** where one option only is to be selected, a **nominal dimension** that needs to be specified, or an **optional feature** that can be removed if not required. Please refer to the back of this page for additional specification details and options.

VISIT BRITEXUSA.COM TO DOWNLOAD THE MOST CURRENT PRODUCT LITERATURE.

NEUTRALIZING TANK

PRODUCT CODE

US-OSNT

TANKS & DRAINAGE

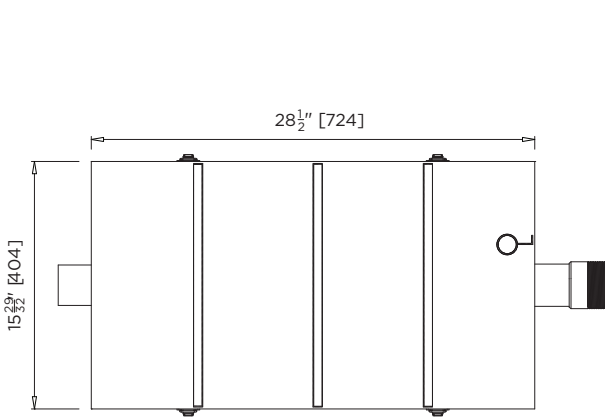

MODEL US-OSNT Plan

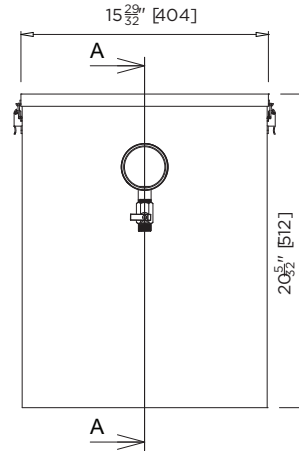

MODEL US-OSNT Front Elevation

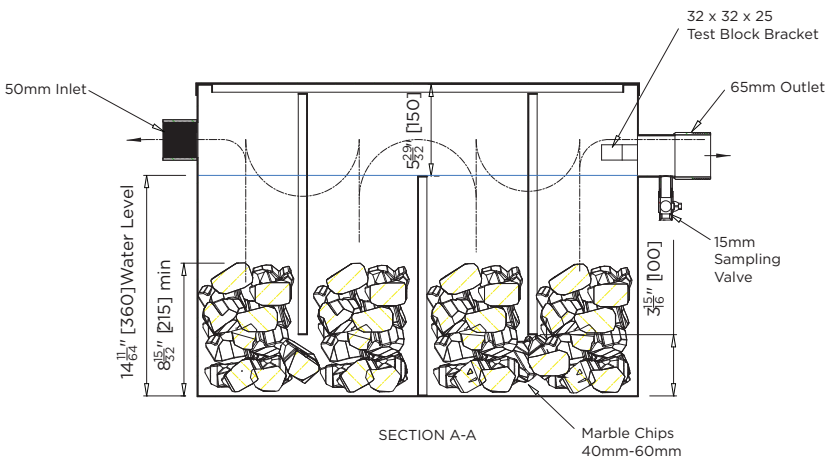

MODEL US-OSNT Side Elevation

When specifying this product please include:

- Product Name and Code
- Product Dimensions

specifying guide

options

- Custom capacity and dimensions

VISIT BRITEXUSA.COM TO DOWNLOAD THE MOST CURRENT PRODUCT LITERATURE.

#US-OSNT / NEUTRALIZING TANK