

GREASE INTERCEPTOR

7.02

TANKS & DRAINAGE

#US-OSGI / GREASE INTERCEPTOR

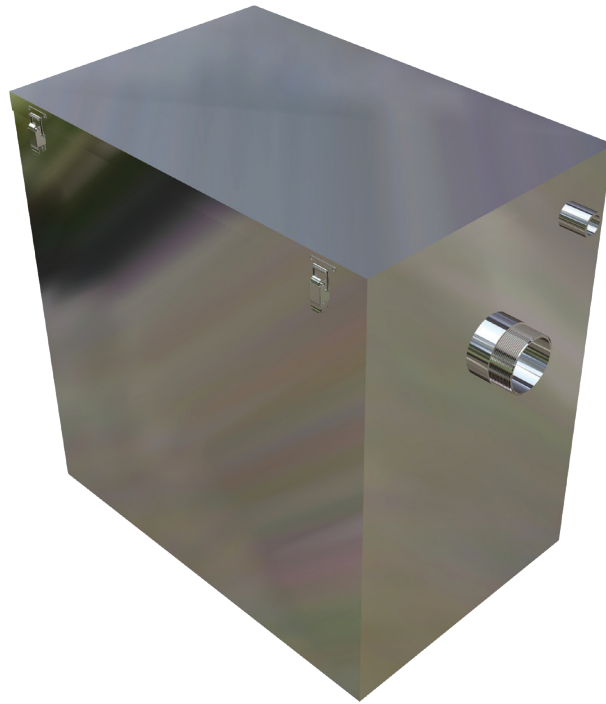

features and benefits

- Sealant rubber gasket under lid
- Quick release lid
- Manufactured from grade 304 S.S.
- Removable cap on outlet pipe to easily dislodge internal blockages
- 100 Litre capacity standard
- Custom sizes available
- Installed above ground
- Ideally suited to commercial kitchens and food preparation areas

about

The *BRITEX Grease Interceptor* is manufactured from 1.2mm grade 304 stainless steel. This unit is generally used in commercial kitchens and food preparation areas to prevent grease and oils entering sewer pipes. The baffle near the inlet slows the flow of water entering the tank, causing the water to cool. Water separation then occurs where heavy solids (grease) sink to the bottom of the tank and oils float to the top, whilst clean water exits through the outlet positioned at the back of the tank. Collected waste is periodically cleaned from the tank by removing the lid that is secured by quick release clips. A cap on the top of the outlet pipe can be removed to dislodge any solids or blockages should they occur. Available in custom and standard sizes as required.

sample spec. text

BRITEX grade 304 S.S. Grease Interceptor - 600L x 400W x 600H O/A. 100 Litre capacity. Outlet to incorporate removable cap. Lid sealed with an internal rubber gasket and quick release clips - Product Code US-OSGI

*RED TEXT may denote a **variable** where one option only is to be selected, a **nominal dimension** that needs to be specified, or an **optional feature** that can be removed if not required. Please refer to the back of this page for additional specification details and options.

VISIT BRITEXUSA.COM TO DOWNLOAD THE MOST CURRENT PRODUCT LITERATURE.

GREASE INTERCEPTOR

PRODUCT CODE

US-OSGI

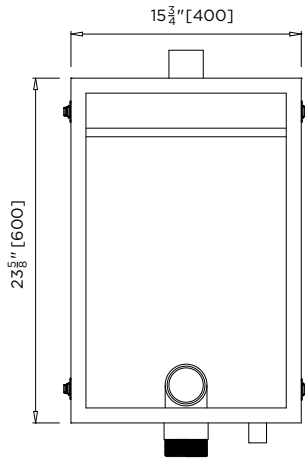

MODEL US-OSGI Plan

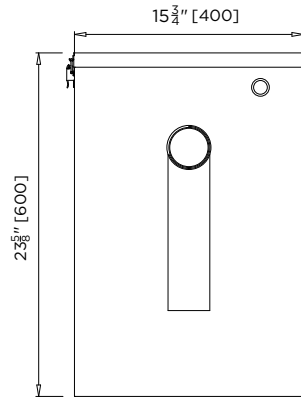

MODEL US-OSGI Front Elevation

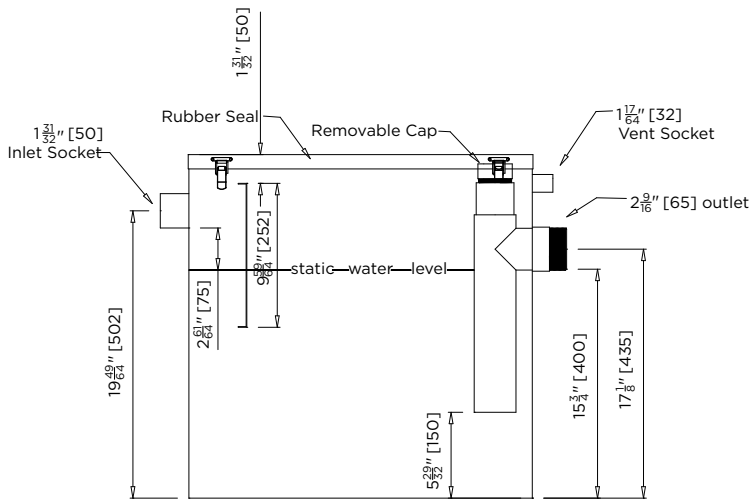

MODEL US-OSGI Side Elevation

When specifying this product please include:

- Product Name and Code
- Product Dimensions

specifying guide

options

- Custom capacity and dimensions

VISIT BRITEXUSA.COM TO DOWNLOAD THE MOST CURRENT PRODUCT LITERATURE.