

CENTURION AMBULANT PAN

2.06

WC-TOILETS

#US-PCAM / CENTURION AMBULANT PAN



features and benefits

- Available with S or P trap
- Concealed fixings
- Unique blockage resistant trap
- Safety radius front edges
- Left and right access panels
- Free of ligature points
- Option for permanently sealed access panels (maximum security projects)
- Suits detention facilities and public amenities

about

The *BRITEX Centurion Ambulant Toilet Pan* is fully shrouded and manufactured from heavy gauge grade 304 satin S.S. making it easy to clean and providing optimal strength. It is designed with respect to ambulant users. Incorporating radius edges for added safety, a pressed internal bowl and unique trap design, the Centurion Ambulant pan is extremely water efficient and much less susceptible to costly blockages in public amenities. Access panels come standard on both sides of the pan for easy installation and a toilet seat can be fitted if required. Britex toilet pans are identified as dual flush "High efficiency water closets" certified with a universal, water consumption dependent on applicable regional regulations. The minimum static water pressure required for operation is 20 Psi (140 kPa) with a maximum static water pressure of 80 Psi (550 kPa). Flushing device should be of an approved capacity and in accordance with local authority requirements.

sample spec. text

BRITEX S.S. Centurion Ambulant Toilet Pan - S/P Trap, 0.5"[14] safety radius front edge, fully shrouded to rear wall and 2 x access panels - Product Code US-PCAMX

*RED TEXT may denote a **variable** where one option only is to be selected, a **nominal dimension** that needs to be specified, or an **optional feature** that can be removed if not required. Please refer to the back of this page for additional specification details and options.

VISIT BRITEXUSA.COM TO DOWNLOAD THE MOST CURRENT PRODUCT LITERATURE.

CENTURION AMBULANT PAN

PRODUCT CODE

US-PCAMS S Trap Model

US-PCAMP P Trap Model

MAXIMUM SECURITY MODEL AVAILABLE

Add '-MS' to the end of the above product codes to specify a maximum security, rear access only model supplied with permanently sealed side access panels.

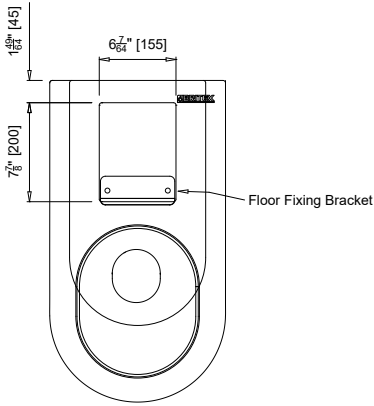

MODEL US-PCAMS / P Plan

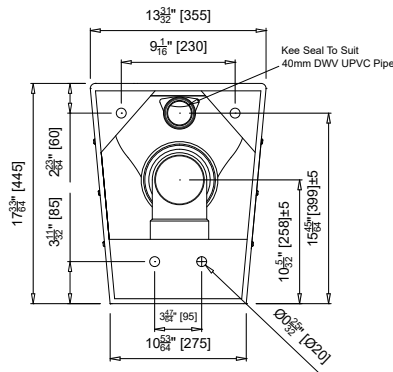

MODEL US-PCAMS Side and Rear Elevation

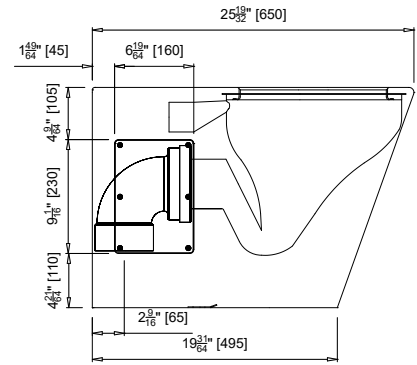

MODEL US-PCAMP Side and Rear Elevation

When specifying this product please include:

- Product Name and Code
- Product Dimensions



VISIT BRITEXUSA.COM TO DOWNLOAD THE MOST CURRENT PRODUCT LITERATURE.



Due to ongoing research and our commitment to product development, details are subject to change without notice. Details accurate at time of print. Please refer to britexusa.com for the most current product information. Allow +/- 5mm tolerance for dimensions and setouts shown in product literature. All dimensions shown in inches ["] are of approximate value only.